

Bus Coupler EC CANopen

RIO EC CANopen

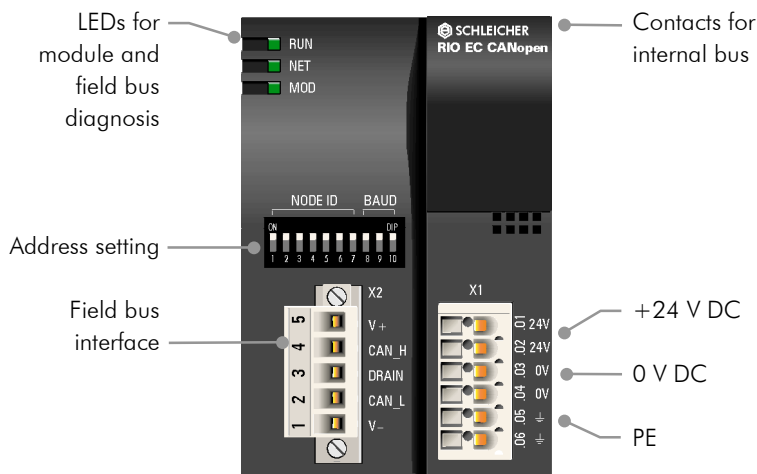

Block diagram

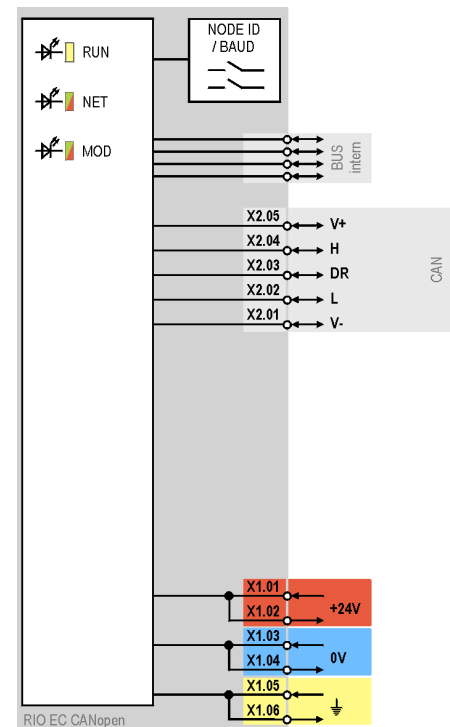

The RIO EC CANopen Economy bus coupler combines the digital, analog and expert modules with the CAN DeviceNet field bus. A bus node comprises the bus coupler and up to eight expansion modules with 128 digital or 56 analog channels.

In order to achieve compatibility with various PLC standards you can use the byte-swap function to swap the two bytes of a data word.

As an Economy bus coupler, the RIO EC CANopen allows you to create an inexpensive bus node. It can be replaced with a BC bus coupler with advanced service and diagnosis functions, without any other alterations.

Technical Data	RIO EC CANopen
Article number	363 157 10
Field bus	CANopen
Bus connection	1 x open style connector 5-pin
Node-ID	Address range 0 ... 127, setting via DIP switches
Baud rate	Up to 1000 Kbaud, setting via DIP switches
Max. I/O range internal	64 bytes input data 64 bytes output data
External supply voltage	DC 24 V ($\pm 20\%$, max. 5% residual ripple)
Power supply to CAN interface	DC 11 ... 30V (meets CAN specification)
Power consumption	Bus coupler: 5 W from external 24 V supply Connected modules: max. 5 W via internal 5 V supply
Number of attachable I/O modules	8
For general technical data see next page	

Technical Data RIO IP20

Electrical data

Supply voltage	24 V DC \pm 20% max. 5% residual ripple
----------------	---

Connection system

Sensors / actuators	Spring terminal
Field bus	Profibus-DP: Subminiature, 9-pin
Supply voltage	Interbus: Screw terminals
	CAN DeviceNet / CANopen: Open style connector
	Spring terminal
Cable cross-section	Finely stranded 0.14 – 1.5 mm ² , single-core 0.5 – 2.5 mm ²

Housing and installation

Type of protection	IP 20 to EN 60529
Dimensions (W x H x D)	RIO microLine PLC: 74.5 x 93 x 51 mm
	RIO BC Bus Couplers: 74.5 x 93 x 51 mm
	RIO EC Bus Couplers: 63 x 93 x 51 mm
	RIO Expansion Modules: 69 x 93 x 51 mm
	RIO Compact I/Os: 69 x 93 x 51 mm
	RIO Terminal Extensions: 69 x 36 x 45 mm
Rail	DIN rail EN 50022-35
Installation position	Vertical, free air circulation

Climatic Conditions

Ambient operating temperature	0 ... +55°C (category KV to DIN 40040)
Storage temperature	-25 ... +70°C (category HS to DIN 40040)
Relative humidity	30 ... 95% (category F to DIN 40040), no condensation
Air pressure in operation	860 ... 1060 hPa

Mechanical strength

Vibration	10 ... 57 Hz constant amplitude 0.075 mm
	57 ... 150 Hz constant acceleration 1 g (to DIN IEC 68-2-6)

Electromagnetic compatibility

Electrostatic discharge	EN 61000-4-2: 4 kV contact discharge
Electromagnetic fields	EN 61000-4-3: field intensity 10 V/m, 80 ... 1000 MHz
Burst	EN 61000-4-4: 2 kV on DC supply lines, 1 kV on I/O signal and serial interface lines
Interference emissions	EN 55011: Limit Category A, Group 1